

TECHNICAL INFORMATION MANUAL

GDS8, GMS8, GHS8 40" 80% Gas Furnace Units

Models listed on
page 3

- Refer to Service Manual RS6610004 for installation, operation, and troubleshooting information.
- All safety information must be followed as provided in the Service Manual.
- Refer to the appropriate Parts Catalog for part number information.

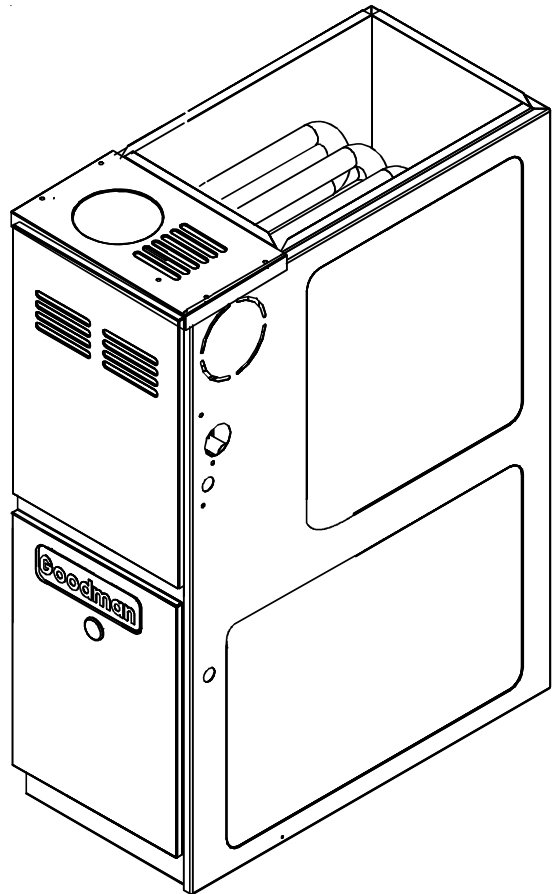
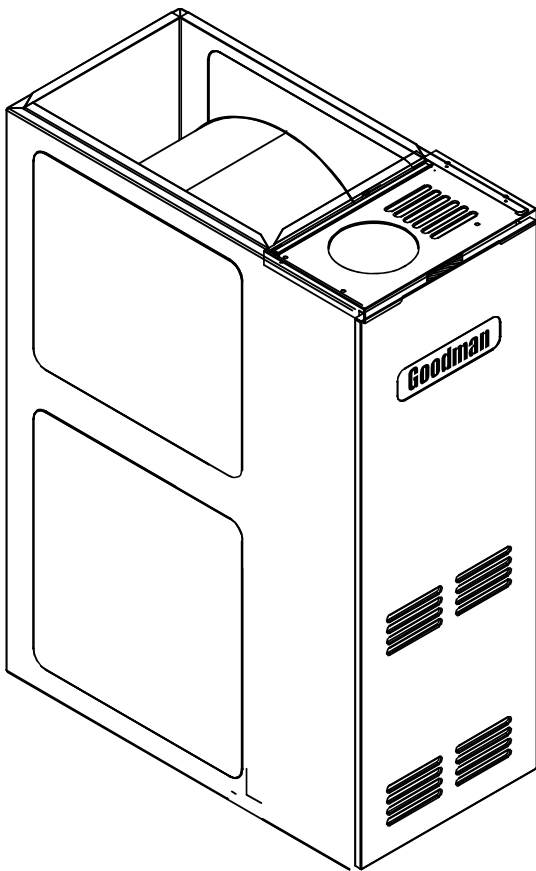

This manual is to be used by qualified, professionally trained HVAC technicians only. Goodman does not assume any responsibility for property damage or personal injury due to improper service procedures performed by an unqualified person.

RT6622004 Rev. 1
September 2007

PRODUCT IDENTIFICATION

The model and manufacturing number are used for positive identification of component parts used in manufacturing. Please use these numbers when requesting service or parts information.

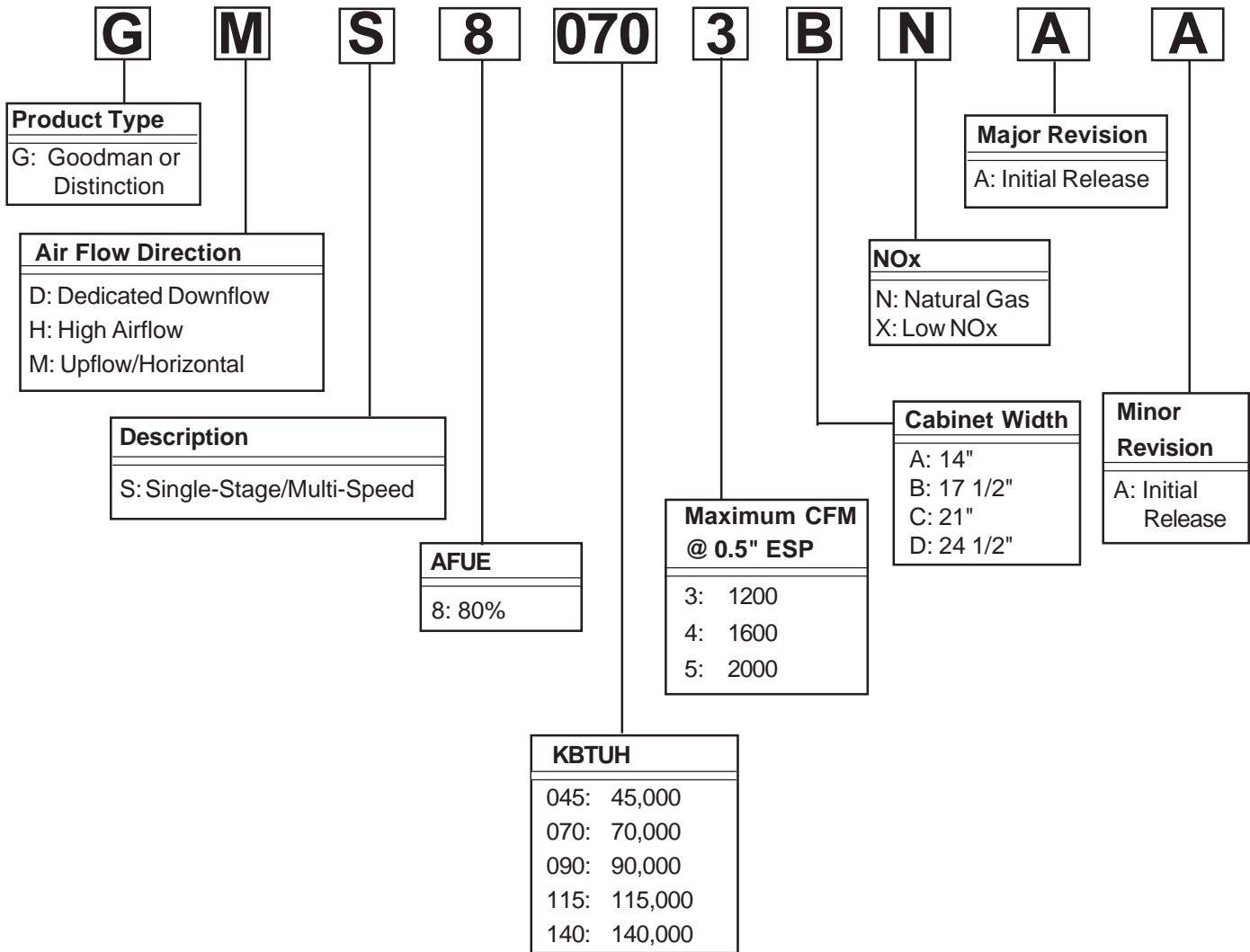

WARNING

HIGH VOLTAGE!
Disconnect ALL power before servicing or installing this unit. Multiple power sources may be present. Failure to do so may cause property damage, personal injury or death.

WARNING

Installation and repair of this unit should be performed ONLY by individuals meeting the requirements of an "entry level technician" as specified by the Air Conditioning and Refrigeration Institute (ARI) may use this information. Attempting to install or repair this unit without such background may result in product damage, personal injury or death.

WARNING

Goodman will not be responsible for any injury or property damage arising from improper service or service procedures. If you install or perform service on this unit, you assume responsibility for any personal injury or property damage which may result. Many jurisdictions require a license to install or service heating and air conditioning equipment.

PRODUCT IDENTIFICATION

The model and manufacturing number are used for positive identification of component parts used in manufacturing. Please use these numbers when requesting service or parts information.

GHS80453AN*
GHS80704BN*
GHS80905CN*
GHS80905CN*

GMS80453AN*
GMS80703AN*
GMS80704BN*
GMS80904BN*
GMS80905CN*
GMS81155CN*
GMS81405DN*

GDS80453AN*
GDS80703AN*
GDS80904BN*
GDS81155CN*

** These models available in Low NOx*



The United States Environmental Protection Agency (“EPA”) has issued various regulations regarding the introduction and disposal of refrigerants introduced into this unit. Failure to follow these regulations may harm the environment and can lead to the imposition of substantial fines. These regulations may vary by jurisdiction. Should questions arise, contact your local EPA office.



To prevent the risk of property damage, personal injury, or death, do not store combustible materials or use gasoline or other flammable liquids or vapors in the vicinity of this appliance.



Do not connect or use any device that is not design certified by Goodman for use with this unit. Serious property damage, personal injury, reduced unit performance and/or hazardous conditions may result from the use of such non-approved devices.

PRODUCT DESIGN

General Operation

The G*S8 furnaces are equipped with an electronic ignition device used to light the burners and an induced draft blower to exhaust combustion products.

An interlock switch prevents furnace operation if the inner blower door is not in place. Keep the blower access door in place except for inspection and maintenance. (See illustration on pages 5 and 6.)

This furnace is also equipped with a self-diagnosing electronic control module. In the event a furnace component is not operating properly, the control module LED will flash on and off in a factory-programmed sequence, depending on the problem encountered. This light can be viewed through the observation window in the blower access door. Refer to the *Troubleshooting Chart* for further explanation of the LED codes and *Abnormal Operation - Integrated Ignition Control* section in the Service Instructions for an explanation of the possible problem.

The rated heating capacity of the furnace should be greater than or equal to the total heat loss of the area to be heated. The total heat loss should be calculated by an approved method or in accordance with "ASHRAE Guide" or "Manual J-Load Calculations" published by the Air Conditioning Contractors of America.

*Obtain from: American National Standards Institute 1430 Broadway New York, NY 10018

Location Considerations

- The furnace should be as centralized as is practical with respect to the air distribution system.
- Do not install the furnace directly on carpeting, tile, or combustible material other than wood flooring.
- When installed in a residential garage, the furnace must be positioned so the burners and ignition source are located not less than 18 inches (457 mm) above the floor and protected from physical damage by vehicles.

Notes:

 WARNING
<p>TO PREVENT POSSIBLE PERSONAL INJURY OR DEATH DUE TO ASPHYXIATION, THIS FURNACE MUST BE CATEGORY I VENTED. DO NOT VENT USING CATEGORY III VENTING.</p>

Category I Venting is venting at a non-positive pressure. A furnace vented as Category I is considered a fan-assisted appliance and the vent system does not have to be "gas tight." **NOTE:** Single stage gas furnaces with induced draft blowers draw products of combustion through a heat exchanger allowing, in some instances, common venting with natural draft appliances (i.e. water heaters). All installations must be vented in accordance with National Fuel Gas Code

NFPA 54/ANSI Z223.1 - latest edition. In Canada, the furnaces must be vented in accordance with the National Standard of Canada, CAN/CSA B149.1 and CAN/CSA B149.2 - latest editions and amendments.

NOTE: The vertical height of the Category I venting system must be at least as great as the horizontal length of the venting system.

Accessibility Clearances (Minimum)

Unobstructed front clearance of 24" for servicing is recommended.

MINIMUM CLEARANCE TO COMBUSTIBLE MATERIALS - INCHES

Sides	Rear	Front*	Vent		Top
			SW	B	
1	0	3	6	1	1

* 24" clearance for serviceability recommended.

** Single Wall Vent (SW) to be used only as a connector.

Refer to the venting tables outlined in the Installation Manual for additional venting requirements.

Note: In all cases accessibility clearance shall take precedence over clearances from the enclosure where accessibility clearances are greater. All dimensions are given in inches.

High Altitude Derate

When this furnace is installed at high altitude, the appropriate High Altitude orifice kit must be installed. This is required due to the natural reduction in the density of both the gas fuel and combustion air as altitude increases. The kit will provide the proper design certified input rate within the specified altitude range.

INPUT PER BURNER - 22,500 BTUH NATURAL GAS / 20,000 BTUH L.P.								
	ELEVATION ABOVE SEA-LEVEL (FEET)							
	2000	3000	4000	4500	5000	6000	7000	8000
US BURNER ORIFICE	44/55	44/55	45/56		45/56	46/57	47/58	47/58
CANADA BURNER ORIFICE	44/55			47/57				

HA-02 HIGH ALTITUDE CONVERSION KIT REQUIRED

Tabular data is based upon the furnace input being reduced for altitudes above sea level. U.S. 4% per 1,000 feet. Canada 10% derate for 2,000-4,000 feet.

High altitude kits are purchased according to the installation altitude and usage of either natural or propane gas. Refer to the chart above for a tabular listing of appropriate altitude ranges and corresponding manufacturer's high altitude Natural Gas and Propane Gas kits. For a tabular listing of appropriate altitude ranges and corresponding manufacturer's High Altitude Pressure Switch kits, refer to either the *Pressure Switch Trip Points & Usage Chart* in this manual or the *Accessory Charts* in Service Instructions.

COMPONENT IDENTIFICATION

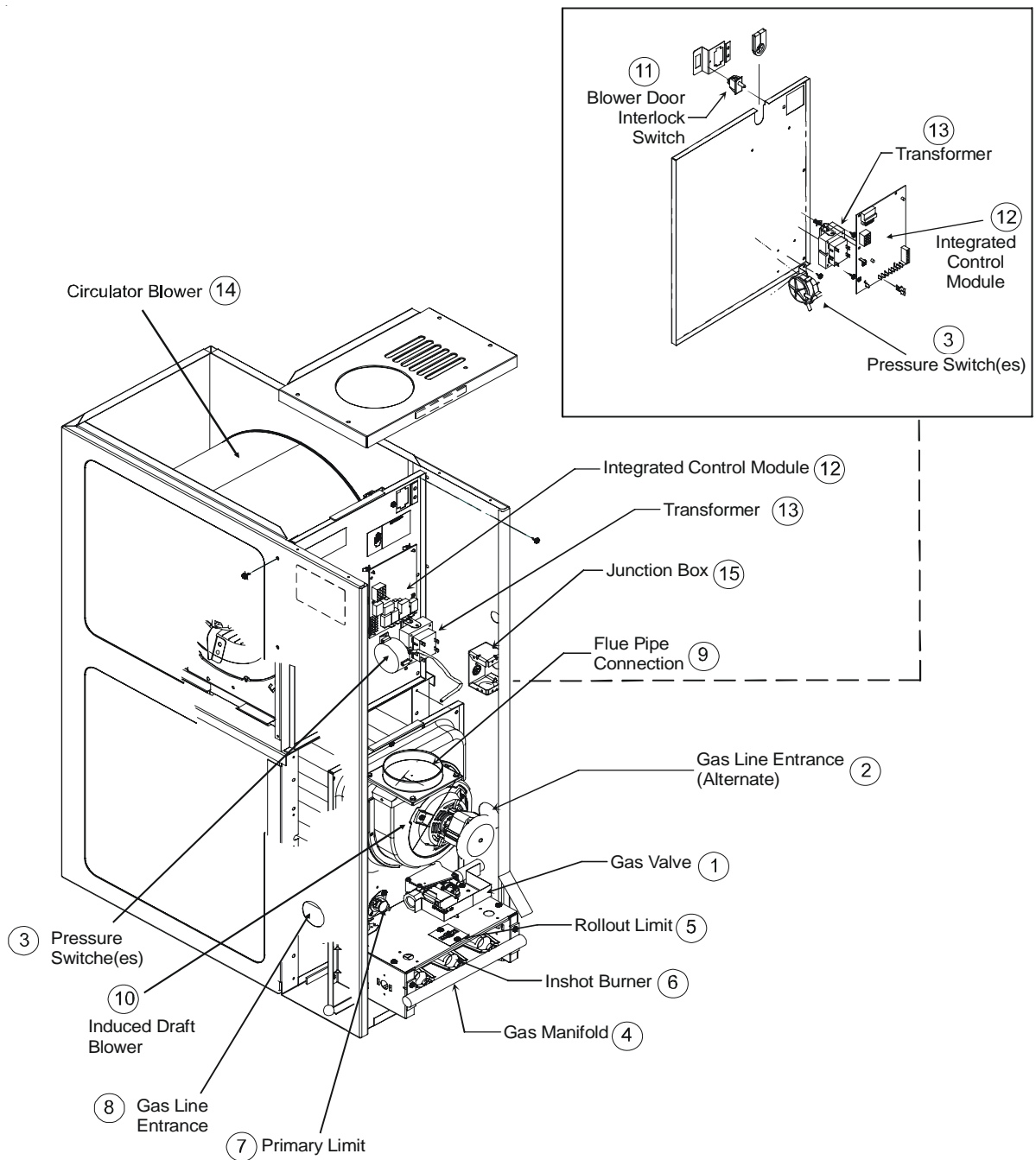

Downflow Models

- | | |
|------------------------------------|--|
| 1 Gas Valve | 10 Induced Draft Blower |
| 2 Gas Line Entrance (Alternate) | 11 Blower Door Interlock Switch |
| 3 Pressure Switch(es) | 12 Integrated Control Module
(with fuse and diagnostic LED) |
| 4 Gas Manifold | 13 Transformer (40 VA) |
| 5 Rollout Limit | 14 Circulator Blower |
| 6 Inshot Burners | 15 Junction Box |
| 7 Primary Limit | |
| 8 Gas Line Entrance | |
| 9 Flue Pipe Connection (Alternate) | |

COMPONENT IDENTIFICATION

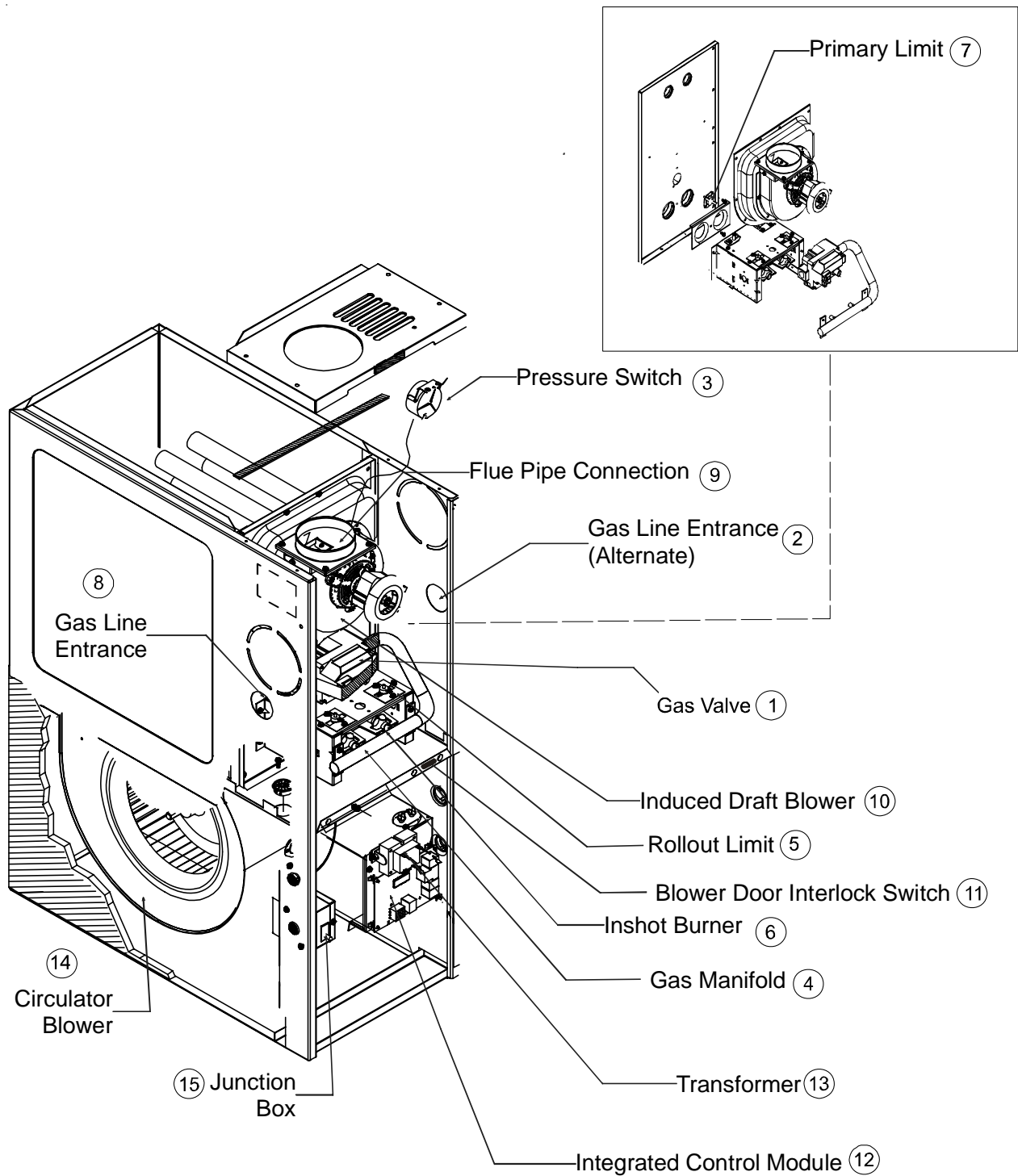

Upflow/Horizontal

- | | |
|------------------------------------|--|
| 1 Gas Valve | 10 Induced Draft Blower |
| 2 Gas Line Entrance (Alternate) | 11 Blower Door Interlock Switch |
| 3 Pressure Switch(es) | 12 Integrated Control Module
(with fuse and diagnostic LED) |
| 4 Gas Manifold | 13 Transformer (40 VA) |
| 5 Rollout Limit | 14 Circulator Blower |
| 7 Primary Limit | 15 Junction Box |
| 8 Gas Line Entrance | |
| 9 Flue Pipe Connection (Alternate) | |

PRODUCT DIMENSIONS

GMS8 / GHS8

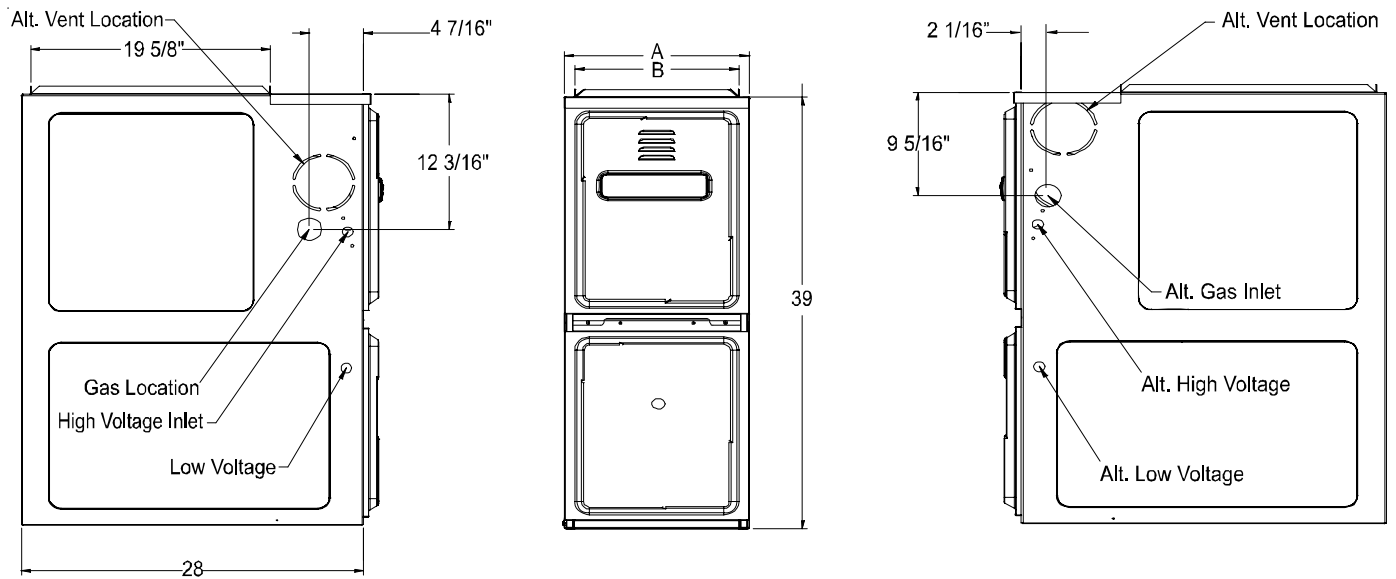

MODEL	A	B
GMS80453A**	14 1/2"	12 1/2"
GMS80703A**	14 1/2"	12 1/2"
GMS80704B**	17 1/2"	16"
GMS80904BN*	17 1/2"	16"
GMS80905B**	21"	19 1/2"
GMS8115CB**	21"	19 1/2"
GMS81405D**	24 1/2"	23"

MODEL	A	B
GHS80453A*	14 1/2"	12 1/2"
GHS80704B**	17 1/2"	16"
GHS80905C**	21"	19 1/2"

PRODUCT DIMENSIONS

GDS8

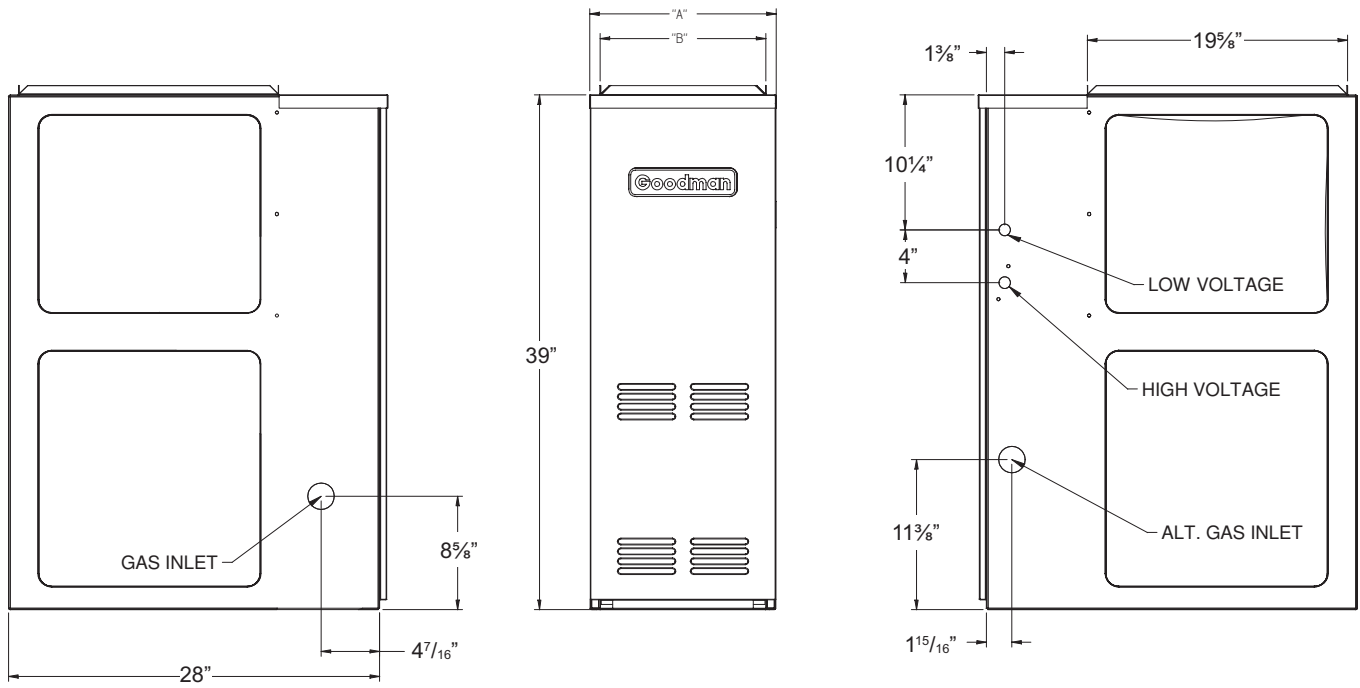

MODEL	A	B
GDS80453A**	14 1/2"	12 1/2"
GDS80703A**	14 1/2"	12 1/2"
GDS80904B**	17 1/2"	16"
GDS81155C**	21"	19 1/2"

PRODUCT DESIGN

GMS8 & GHS8

Pressure Switch Trip Points And Usage Chart Square Nose		
Model	Trip Point ID Blower Pressure Switch	ID Blower Pressure Switch Part #
GMS80453A**	-0.60	B1370142
GMS80703A**	-0.60	B1370142
GMS80704B**	-0.60	B1370142
GMS80904B**	-0.60	B1370142
GMS80905B**	-0.70	B1370158
GMS8115CB**	-0.70	B1370158
GMS81405D**	-0.75	13070159

GHS80453A**	-0.60	B1370142
GHS80704B**	-0.60	B1370142
GHS80905C**	-0.70	B1370158

Pressure Switch Trip Points And Usage Chart Round Nose		
Model	Trip Point ID Blower Pressure Switch	ID Blower Pressure Switch Part #
GMS80453A**	-0.60	B1370142
GMS80703A**	-0.60	B1370142
GMS80704B**	-0.47	B1370176
GMS80904B**	-0.75	B1370179
GMS80905B**	-0.60	B1370142
GMS8115CB**	-0.70	B1370158
GMS81405D**	-0.60	13070142

GHS80453A**	-0.60	B1370142
GHS80704B**	-0.47	B1370176
GHS80905C**	-0.60	B1370142

For installations in Canada, the GMS and GHS furnaces are certified only to 4,500 ft.

* Negative pressure readings are in inches of water column (*w.c.)

T.O.D. PRIMARY LIMIT					
Part Number	B1370190	B1370187	B1370188	B1370198	B1370189
Open Setting (°F)	210	160	170	150	200
GMS80453A**	1	---	---	---	---
GMS80703A**	---	1	---	---	---
GMS80704B**	---	---	1	---	---
GMS80904B**	---	---	1	---	---
GMS80905B**	---	---	---	---	1
GMS8115CB**	---	---	---	1	---
GMS81405D**	---	---	---	1	---

GHS80453A**	1	---	---	---	---
GHS80704B**	---	---	1	---	---
GHS80905C**	---	---	---	---	1

ROLLOUT LIMIT SWITCHES	
Part Number	B1370145
Open Setting (°F)	300
GMS80453A**	2
GMS80703A**	2
GMS80704B**	2
GMS80904B**	2
GMS80905B**	2
GMS8115CB**	2
GMS81405D**	2

GHS80453A**	2
GHS80704B**	2
GHS80905C**	2

AUXILIARY LIMIT SWITCHES	
Part Number	B1370155
Open Setting (°F)	120
GMS80453A**	1
GMS80703A**	1
GMS80704B**	1
GMS80904B**	1
GMS80905B**	1
GMS8115CB**	1
GMS81405D**	1

GHS80453A**	1
GHS80704B**	1
GHS80905C**	1

Pressure Switches		
Model	Part No.	Opens*
GDS80453A**	B1370142	-0.60
GDS80703A**	B1370142	-0.60
GDS80904B**	B1370142	-0.60
GDS81155C**	B137158	-0.70

T.O.D. PRIMARY LIMIT		
Part Number	B1370194	0130F00015
Open Setting (°F)	250	280
GDS80453A**	1	---
GDS80703A**	1	---
GDS80904B**	---	1
GDS81155C**	1	---

ROLLOUT LIMIT SWITCHES	
Part Number	B1370145
Open Setting (°F)	300
GDS80453A**	2
GDS80703A**	2
GDS80904B**	2
GDS81155C**	2

AUXILIARY LIMIT SWITCHES	
Part Number	B1370155
Open Setting (°F)	120
GDS80453A**	1
GDS80703A**	1
GDS80904B**	1
GDS81155C**	1

PRODUCT DESIGN

Coil Matches:

A large array of Amana® brand coils are available for use with the GMS8 and GHS8 furnaces, in either upflow or horizontal applications and for the GDS8 for downflow applications. These coils are available in both cased and uncased models, with or without a TXV expansion device. These 80% furnaces match up with the existing Amana® brand coils as shown below.

Coil Matches (for Goodman® units using R22 and R-410A):

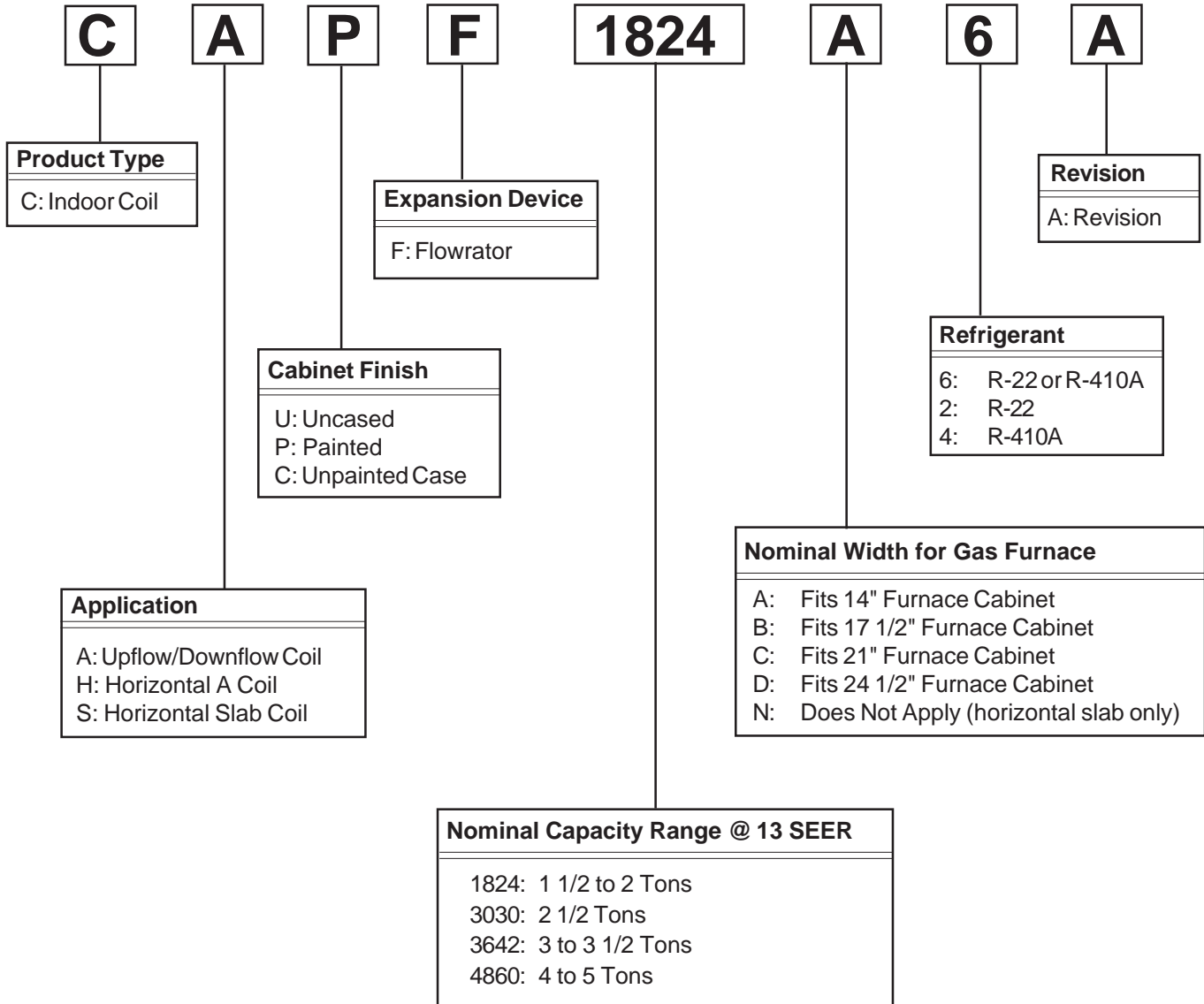

- All CAPF coils in B, C, & D widths have insulated blank off plates for use with one size smaller furnaces.
- All CAPF coils have a CAUF equivalent.
- All CHPF coils in B, C & D heights have an insulated Z bracket for use with one size smaller furnace.
- All proper coil combinations are subject to being ARI rated with a matched outdoor unit.

PRODUCT DESIGN

Thermostats:

The following Amana® brand thermostats are suggested for use with G*S8 Furnace Models:

THERMOSTATS						
Thermostat	Man/Auto	Programmable	Cool	Heat	Batt. Powered	Batt. Bkup
1213406*	Man. Or Auto	Yes	2	3	No	No
1213407	Man. Changeover	Yes	2	2	Yes	Yes
1213411	Man. Changeover	No	2	2	Yes	No

*1213406 is the recommended model for the G*S* furnaces when used with a heat pump in a fossil fuel application. It is NOT for use with the G*S8 as a sole heating source. 1213406 thermostats are 24V powered with battery backup.

Filters:

Filters are required with this furnace and must be provided by the installer. The filters used must comply with UL900 or CAN/ULCS111 standards. Installing this furnace without filters will void the unit warranty

Upflow Filters

This furnace has provisions for the installation of return air filters at the side and/or bottom return. The furnace will accommodate the following filter sizes depending on cabinet size:

SIDE RETURN		
Cabinet Width (in.)	Nominal Filter Size (in.)	Approx. Flow Area (in ²)
All	16 x 25 x 1	400

BOTTOM RETURN		
Cabinet Width (in.)	Nominal Filter Size (in.)	Approx. Flow Area (in ²)
17-1/2	14 x 25 x 1	350
21	16 x 25 x 1	400
24-1/2	20 x 25 x 1	500

Refer to Minimum Filter Area tables to determine filter area requirement. **NOTE:** Filters can also be installed elsewhere in the duct system such as a central return.

		UPFLOW COOLING AIRFLOW REQUIREMENT (CFM)						
		600	800	1000	1200	1400	1600	2000
Input Airflow	0704_XA	---	---	564*	564*	672	768	
	0905_XA	---	---	---	752*	752*	768	960
	1155_XA	---	---	---	940*	940*	940*	960

		UPFLOW COOLING AIRFLOW REQUIREMENT (CFM)						
		600	800	1000	1200	1400	1600	2000
Input Airflow	0704_XA	---	---	627*	627*	672	768	---
	0905_XA	---	---	---	836*	836*	836*	960
	1155_XA	---	---	---	940*	940*	940*	960

		COUNTERFLOW COOLING AIRFLOW REQUIREMENT (CFM)						
		600	800	1000	1200	1400	1600	2000
Input Airflow	0704_XA	---	---	641*	641*	672	768	---
	0905_XA	---	---	---	854*	854*	854*	960

		COUNTERFLOW COOLING AIRFLOW REQUIREMENT (CFM)						
		600	800	1000	1200	1400	1600	2000
Input Airflow	0704_XA	---	---	320*	320*	336	384	---
	0905_XA	---	---	---	427*	427*	427*	480

*Minimum filter area dictated by heating airflow requirement.

*Minimum filter area dictated by heating airflow requirement.

Disposable Minimum Filter Area (in²)

[Based on a 300 ft/min filter face velocity]

Permanent Minimum Filter Area (in²)

[Based on 600 ft/min filter face velocity]

PRODUCT DESIGN

Counterflow Filters

This furnace has provisions for the installation of return air filters at the counterflow top return. The furnace will accommodate the following filter sizes depending on cabinet size:

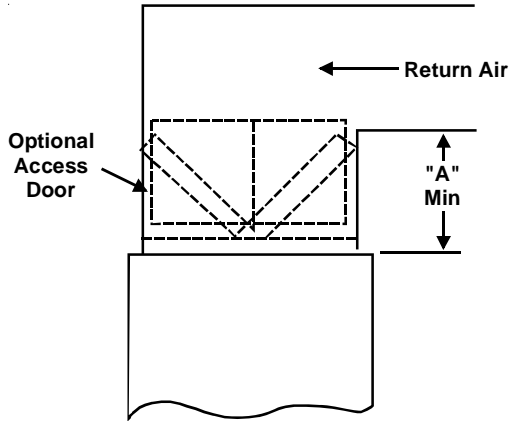

Counterflow Top Return				
Cabinet Width	Filter Area (in ²)	Qty	Filter Size (in)	Dimension "A" (in)
21	600	2	15 X 20 X 1	13.0
24 1/2				11.3
21	800	2	20 X 20 X 1	18.8
24 1/2				17.7
21	1000	2	25 X 20 X 1	24.3
24 1/2				23.4

Refer to Minimum Filter Area tables to determine filter area requirement. **NOTE:** Filters can also be installed elsewhere in the duct system such as a central return.

FURNACE SPECIFICATIONS

GDS8

MODEL	GDS80453A**	GDS80703A**	GDS80904B**	GDS81155C**
Btuh Input (US) High Fire	45,000	70,000	90,000	115,000
Output (US) High Fire	36,000	56,000	72,000	92,000
A.F.U.E.	80%	80%	80%	80%
Rated External Static (" w.c.)	.20 - .50	.20 - .50	.20 - .50	.20 - .50
Temperature Rise (°F)	25 - 55	25 - 55	30 - 60	40 - 70
High Stage Pressure Switch Trip Point (" w.c.)	-0.60	-0.60	-0.60	-0.70
Blower Wheel (D" x W")	10 X 6	10 x 6	10 x 8	10 x 10
Blower Horsepower	1/3	1/3	1/2	1/2
Blower Speeds	4	4	4	4
Max CFM @ 0.5 E.S.P.	1200	1200	1600	2000
Power Supply	115-60-1	115-60-1	115-60-1	115-60-1
Minimum Circuit Ampacity (MCA) ⁽¹⁾	8.5	8.5	12.9	12.9
Maximum Overcurrent Device ⁽²⁾	15	15	15	15
Transformer (VA)	40	40	40	40
Heat Anticipator (Amps)	0.7	0.7	0.7	0.7
Primary Limit Setting (°F)	250	250	250	250
Auxiliary Limit Setting (°F)	120	120	120	120
Rollout Limit Setting (°F)	300	300	300	300
Gas Supply Pressure (Natural/Propane) (" w.c.)	7 / 11	7 / 11	7 / 11	7 / 11
Manifold Pressure (Natural/Propane) High Stage (" w.c.)	3.5 / 10	3.5 / 10	3.5 / 10	3.5 / 10
Orifice Size (Natural/Propane)	#43 / #55	#43 / #55	#43 / #55	#43 / #55
Number of Burners	2	3	4	5
Vent Connector Diameter (inches) ⁽³⁾	4	4	4	4
Shipping Weight (lbs.)	120	130	153	175

⁽¹⁾ Wire size should be determined in accordance with National Electrical Codes. Extensive wire runs will require larger wire sizes.

⁽²⁾ Maximum Overcurrent Protection Device: May use Time Delay Fuse or HACR type Circuit Breaker of the same size as noted.

⁽³⁾ See Installation Instructions for appropriate vent diameter, length and number of elbows.

1. These furnaces are manufactured for natural gas operation. Optional Kits are available for conversion to propane gas operation.
2. For elevations above 2000 ft. the rating should be reduced by 4% for each 1000 ft. above sea level. The furnace must not be derated, orifice changes should only be made if necessary for altitude.
3. The total heat loss from the structure as expressed in TOTAL BTU/HR must be calculated by the manufactures method in accordance with the "A.S.H.R.A.E. GUIDE" or "MANUAL J-LOAD CALCULATIONS" published by the AIR CONDITIONING CONTRACTORS OF AMERICA. The total heat loss calculated should be equal to or less than the heating capacity. Output based on D.O.E. test procedures, steady state efficiency times output.
4. Minimum Circuit Ampacity calculated as: (1.25 x Circulator Blower Amps) + I.D. Blower Amps.

Unit specifications are subject to change without notice. **ALWAYS** refer to the unit's serial plate for the most up-to-date general and electrical information.

FURNACE SPECIFICATIONS

GMS8

MODEL	GMS80453A**	GMS80703A**	GMS80704B**	GMS80904B**	GMS80905C**	GMS81155C**	GMS81405D**
Btuh Input (US) High Fire	45,000	70,000	70,000	90,000	90,000	115,000	115,000
Output (US) High Fire	36,000	56,000	56,000	72,000	72,000	92,000	92,000
A.F.U.E.	80%	80%	80%	80%	80%	80%	80%
Rated External Static (" w.c.)	.20 - .50	.20 - .50	.20 - .50	.20 - .50	.20 - .50	.20 - .50	.20 - .50
Temperature Rise (°F)	20 - 50	20 - 50	20 - 50	30 - 60	30 - 60	40 - 70	40 - 70
High Stage Pressure Switch Trip Point (" w.c.)	-0.60	-0.60	-0.60	-0.60	-0.60	-0.70	-0.70
Blower Wheel (D" x W")	10 X 6	10 x 6	10 x 8	10 x 8	10 x 10	10 x 10	10 x 10
Blower Horsepower	1/3	1/3	1/2	1/2	1/2	1/2	1/2
Blower Speeds	4	4	4	4	4	4	4
Max CFM @ 0.5 E.S.P.	1200	1200	1600	1600	2000	2000	2000
Power Supply	115-60-1	115-60-1	115-60-1	115-60-1	115-60-1	115-60-1	115-60-1
Minimum Circuit Ampacity (MCA) ⁽¹⁾	8.5	8.5	12.9	12.9	12.9	12.9	12.9
Maximum Overcurrent Device ⁽²⁾	15	15	15	15	15	15	15
Transformer (VA)	40	40	40	40	40	40	40
Heat Anticipator (Amps)	0.7	0.7	0.7	0.7	0.7	0.7	0.7
Primary Limit Setting (°F)	250	250	250	250	250	250	250
Auxiliary Limit Setting (°F)	120	120	120	120	120	120	120
Rollout Limit Setting (°F)	300	300	300	300	300	300	300
Gas Supply Pressure (Natural/Propane) (" w.c.)	7 / 11	7 / 11	7 / 11	7 / 11	7 / 11	7 / 11	7 / 11
Manifold Pressure (Natural/Propane) High Stage (" w.c.)	3.5 / 10	3.5 / 10	3.5 / 10	3.5 / 10	3.5 / 10	3.5 / 10	3.5 / 10
Orifice Size (Natural/Propane)	#43 / #55	#43 / #55	#43 / #55	#43 / #55	#43 / #55	#43 / #55	#43 / #55
Number of Burners	2	3	3	4	4	5	5
Vent Connector Diameter (inches) ⁽³⁾	4	4	4	4	4	4	4
Shipping Weight (lbs.)	120	130	143	153	163	175	175

⁽¹⁾ Wire size should be determined in accordance with National Electrical Codes. Extensive wire runs will require larger wire sizes.

⁽²⁾ Maximum Overcurrent Protection Device: May use Time Delay Fuse or HACR type Circuit Breaker of the same size as noted.

⁽³⁾ See Installation Instructions for appropriate vent diameter, length and number of elbows.

1. These furnaces are manufactured for natural gas operation. Optional Kits are available for conversion to propane gas operation.
2. For elevations above 2000 ft. the rating should be reduced by 4% for each 1000 ft. above sea level. The furnace must not be derated, orifice changes should only be made if necessary for altitude.
3. The total heat loss from the structure as expressed in TOTAL BTU/HR must be calculated by the manufactures method in accordance with the "A.S.H.R.A.E. GUIDE" or "MANUAL J-LOAD CALCULATIONS" published by the AIR CONDITIONING CONTRACTORS OF AMERICA. The total heat loss calculated should be equal to or less than the heating capacity. Output based on D.O.E. test procedures, steady state efficiency times output.
4. Minimum Circuit Ampacity calculated as: (1.25 x Circulator Blower Amps) + I.D. Blower Amps.

Unit specifications are subject to change without notice. **ALWAYS** refer to the unit's serial plate for the most up-to-date general and electrical information.

FURNACE SPECIFICATIONS

GHS8

MODEL	GHS80453A**	GHS80704B**	GHS80905C**
Input, Natural Gas (BTUH)	45,000	70,000	90,000
Output, Natural Gas (BTUH)	36,000	56,000	72,000
Output, LP (BTUH)	32,000	48,000	64,000
A.F.U.E.	80.0%	80.0%	80.0%
Rated External Static (" w.c.)	0.20 - 0.50	0.20 - 0.50	0.20 - 0.50
Temperature Rise (°F)	25 - 55	20 - 50	35 - 65
Pressure Switch Trip Point (" w.c.)	-0.60	-0.60	-0.70
Blower Wheel (D" x W")	10x6	10x8	10x10
Blower Horsepower	1/3	1/2	1/2
Blower Speeds	4	4	4
Max CFM @ 0.5 E.S.P.	1200	1600	2000
Power Supply (Volts/Hz/Ph)	115/60/1	115/60/1	115/60/1
Minimum Circuit Ampacity (MCA) ⁽¹⁾	8.1	12.5	12.5
Maximum Overcurrent Device ⁽²⁾	15	15	15
Transformer (VA)	40	40	40
ID Blower Pressure Switch Trip Point (" w.c.) Square Nose Blowers	-.60	-.60	-.70
ID Blower Pressure Switch Trip Point (" w.c.) Round Nose Blowers	-.60	-.47	-.60
Primary Limit Setting (°F)	210	170	200
Auxiliary Limit Setting (°F)	120	120	120
Rollout Limit Setting (°F)	300	300	300
Gas Supply Pressure (Natural/Propane) (" w.c.)	7 / 11	7 / 11	7 / 11
Manifold Pressure (Natural/Propane) (" w.c.)	3.5 / 10	3.5 / 10	3.5 / 10
Orifice Size (Natural/Propane)	43 / 55	43 / 55	43 / 55
Number of Burners	2	3	4
Vent Connector Diameter (inches) ⁽³⁾	4	4	4
Shipping Weight (lbs.)	120	143	163

⁽¹⁾ Wire size should be determined in accordance with National Electrical Codes. Extensive wire runs will require larger wire sizes.

⁽²⁾ Maximum Overcurrent Protection Device: May use Time Delay Fuse or HACR type Circuit Breaker of the same size as noted.

⁽³⁾ See Installation Instructions for appropriate vent diameter, length and number of elbows.

1. These furnaces are manufactured for natural gas operation. Optional Kits are available for conversion to propane gas operation.
2. For elevations above 2000 ft. the rating should be reduced by 4% for each 1000 ft. above sea level. The furnace must not be derated, orifice changes should only be made if necessary for altitude.
3. The total heat loss from the structure as expressed in TOTAL BTU/HR must be calculated by the manufactures method in accordance with the "A.S.H.R.A.E. GUIDE" or "MANUAL J-LOAD CALCULATIONS" published by the AIR CONDITIONING CONTRACTORS OF AMERICA. The total heat loss calculated should be equal to or less than the heating capacity. Output based on D.O.E. test procedures, steady state efficiency times output.
4. Minimum Circuit Ampacity calculated as: (1.25 x Circulator Blower Amps) + I.D. Blower Amps.

Unit specifications are subject to change without notice. **ALWAYS** refer to the unit's serial plate for the most up-to-date general and electrical information.

BLOWER PERFORMANCE SPECIFICATIONS

GMS8

BLOWER PERFORMANCE (CFM & Temperature Rise vs. External Static Pressure)															
Model (Heating Speed As Shipped)	Motor Speed	Tons AC at 0.5" ESP	EXTERNAL STATIC PRESSURE (Inches Water Column)												
			0.1		0.2		0.3		0.4		0.5		0.6	0.7	0.8
			CFM	RISE	CFM	RISE	CFM	RISE	CFM	RISE	CFM	RISE	CFM	CFM	CFM
GMS80453AN* (MEDIUM)	HIGH	3.0	1555	---	1511	---	1459	---	1392	---	1344	25	1279	1201	1120
	MED	2.5	1165	28	1123	30	1100	30	1090	30	1048	32	1017	970	90.3
	MED-LO	2.0	927	36	907	37	889	37	863	38	853	39	822	800	746
	LOW	1.5	699	47	694	48	668	50	645	51	636	52	592	566	524
GMS80703AN* (MEDIUM)	HIGH	3.0	1447	36	1310	39	1295	40	1310	39	1273	41	1202	1129	1039
	MED	2.5	1127	46	1100	47	1095	47	1075	48	1050	49	1018	967	904
	MED-LO	2.0	895	---	917	---	878	---	867	---	853	---	830	786	743
	LOW	1.5	694	---	681	---	663	---	640	---	625	---	591	562	522
GMS80704BN* (MEDIUM)	HIGH	4.0	2234	23	2151	24	2076	25	1990	26	1897	27	1803	1710	1569
	MED	3.5	1676	31	1653	31	1648	31	1581	33	1555	33	1492	1414	1352
	MED-LO	3.0	1342	38	1335	39	1321	39	1313	39	1291	40	1261	1215	1149
	LOW	2.5	1089	47	1085	48	1078	48	1071	48	1057	49	1040	956	932
GMS80904BN* (MEDIUM)	HIGH	4.0	2182	---	2127	31	2056	32	1974	33	1895	35	1809	1715	1588
	MED	3.5	1645	40	1628	40	1615	40	1597	41	1541	43	1491	1440	1350
	MED-LO	3.0	1320	49	1305	49	1310	49	1310	50	1295	51	1267	1217	1139
	LOW	2.5	1063	60	1061	60	1057	61	1056	61	1039	61	1025	1005	948
GMS80905CN* (MEDIUM)	HIGH	5.0	2334	---	2334	---	2284	---	2135	---	2051	35	1910	1748	1605
	MED	4.0	1754	39	1735	39	1728	40	1685	40	1628	42	1551	1469	1346
	MED-LO	3.5	1367	47	1380	47	1371	47	1374	48	1335	50	1293	1246	1165
	LOW	3.0	1098	58	1109	59	1109	59	1088	60	1066	62	1050	998	916
GMS81155CN* (MEDIUM)	HIGH	5.0	2481	---	2395	35	2288	37	2217	38	2076	41	1999	1858	1732
	MED	4.0	1738	49	1732	49	1709	50	1686	50	1639	52	1585	1492	1385
	MED-LO	3.5	1364	62	1378	62	1372	62	1372	62	1350	63	1313	1261	1125
	LOW	3.0	1137	---	1142	---	1140	---	1114	---	1090	---	1056	954	860
GMS81405DN* (MEDIUM)	HIGH	5.0	2554	41	2435	43	2375	44	2240	47	2152	49	2002	1883	1744
	MED	4.0	1846	57	1773	59	1762	60	1712	61	1672	63	1583	1526	1442
	MED-LO	3.5	1520	69	1500	70	1483	---	1470	---	1435	---	1373	1308	1245
	LOW	3.0	1301	---	1274	---	1260	---	1231	---	1207	---	1177	1093	931

NOTES:

- CFM in chart is without filter(s). Filters do not ship with this furnace, but must be provided by the installer.
- All furnaces ship as high-speed cooling. Installer must adjust blower cooling speed as needed.
- For most jobs, about 400 CFM per ton when cooling is desirable
- INSTALLATION IS TO BE ADJUSTED TO OBTAIN TEMPERATURE RISE WITHIN THE RANGE SPECIFIED ON THE RATING PLATE.
- The chart is for information only. For satisfactory operation, external static pressure must not exceed values shown on the rating plate. The shaded area insicated ranges in excess of maximum static pressure allowed when heating.
- The dashed (---) areas indicate a temperature rise not recommended for this model.
- The above chart is for U.S. furnaces installed at 0' - 2,000'. At higher altitudes, a properly de-rated unit will have approximatley the same temperature rise at a particular CFM, while ESP at the CFM will be lower.

BLOWER PERFORMANCE SPECIFICATIONS

GHS8

BLOWER PERFORMANCE (CFM & Temperature Rise vs. External Static Pressure)															
Model (Heating Speed As Shipped)	Motor Speed	Tons AC at 0.5" ESP	EXTERNAL STATIC PRESSURE (Inches Water Column)												
			0.1		0.2		0.3		0.4		0.5		0.6	0.7	0.8
			CFM	RISE	CFM	RISE	CFM	RISE	CFM	RISE	CFM	RISE	CFM	CFM	CFM
GHS80453AX* (MEDIUM)	HIGH	3.0	1654	---	1647	---	1605	---	1537	---	1499	---	1493	1406	1307
	MED	2.5	1489	---	1463	---	1456	---	1416	---	1403	---	1346	1271	1185
	MED-LO	2.0	1349	25	1282	26	1246	27	1235	27	1218	27	1187	1128	1051
	LOW	1.5	1088	30	1086	31	1082	31	1069	31	1045	32	1013	968	908
GHS80704BX* (MEDIUM)	HIGH	4.0	2040	25	1991	26	1942	27	1912	27	1891	27	1850	1828	1785
	MED	3.5	1563	33	1527	34	1490	35	1461	35	1444	36	1423	1401	1370
	LOW	3.0	1165	44	1149	45	1133	46	1122	46	1111	46	1089	1048	994
GHS80905CX* (MEDIUM)	HIGH	5.0	2402	---	2321	---	2265	---	2193	---	2134	---	2057	1962	1895
	MED	4.0	1754	38	1718	39	1661	40	1622	41	1581	42	1519	1433	1387
	LOW	3.5	1266	52	1234	54	1177	56	1143	58	1071	62	1024	964	878

NOTES:

- CFM in chart is without filter(s). Filters do not ship with this furnace, but must be provided by the installer.
- All furnaces ship as high-speed cooling. Installer must adjust blower cooling speed as needed.
- For most jobs, about 400 CFM per ton when cooling is desirable
- INSTALLATION IS TO BE ADJUSTED TO OBTAIN TEMPERATURE RISE WITHIN THE RANGE SPECIFIED ON THE RATING PLATE.
- The chart is for information only. For satisfactory operation, external static pressure must not exceed values shown on the rating plate. The shaded area indicated ranges in excess of maximum static pressure allowed when heating.
- The dashed (---) areas indicate a temperature rise not recommended for this model.
- The above chart is for U.S. furnaces installed at 0' - 2,000'. At higher altitudes, a properly de-rated unit will have approximately the same temperature rise at a particular CFM, while ESP at the CFM will be lower.

BLOWER PERFORMANCE SPECIFICATIONS

GDS8

BLOWER PERFORMANCE (CFM & Temperature Rise vs. External Static Pressure)															
Model (Heating Speed As Shipped)	Motor Speed	Tons AC at 0.5" ESP	EXTERNAL STATIC PRESSURE (Inches Water Column)												
			0.1		0.2		0.3		0.4		0.5		0.6	0.7	0.8
			CFM	RISE	CFM	RISE	CFM	RISE	CFM	RISE	CFM	RISE	CFM	CFM	CFM
GDS80453AX* (MEDIUM)	HIGH	3.0	1435	---	1421	---	1380	---	1322	25	1262	26	1200	1144	1064
	MED	2.5	1140	29	1114	30	1084	31	1063	31	1039	32	1002	943	897
	MED-LO	2.0	899	37	889	37	875	38	871	38	857	39	821	780	745
	LOW	1.5	691	48	674	49	665	50	651	51	637	52	618	562	525
GDS80703AX* (MEDIUM)	HIGH	3.0	1406	37	1393	37	1379	37	1307	39	1262	41	1208	1145	1070
	MED	2.5	1153	45	1101	347	1077	48	1039	50	1028	50	987	947	885
	MED-LO	2.0	890	58	896	58	873	59	862	60	834	---	798	771	727
	LOW	1.5	690	---	682	---	664	---	631	---	616	---	583	549	509+
GDS80904BX* (MEDIUM)	HIGH	4.0	2007	---	1993	---	1975	---	1940	---	1844	36	1770	1668	1559
	MED	3.5	1612	41	1606	41	1570	42	1533	43	1501	44	1448	1373	1301
	MED-LO	3.0	1325	50	1299	51	1280	52	1244	53	1222	54	1186	1140	1079
	LOW	2.5	1043	64	1040	64	1032	64	1002	---	981	---	955	915	869
GDS81155CX* (MEDIUM)	HIGH	5.0	2381	---	2312	---	2312	---	2219	---	2134	40	2024	1930	1839
	MED	4.0	1801	47	1801	51	1667	51	1638	52	1613	53	1513	1441	1369
	MED-LO	3.5	969	---	969	---	1140	---	1223	69	1269	67	1292	1322	1358
	LOW	3.0	1100	---	1100	---	1060	---	1031	---	1001	---	953	937	874

NOTES:

- CFM in chart is without filter(s). Filters do not ship with this furnace, but must be provided by the installer.
- All furnaces ship as high-speed cooling. Installer must adjust blower cooling speed as needed.
- For most jobs, about 400 CFM per ton when cooling is desirable
- INSTALLATION IS TO BE ADJUSTED TO OBTAIN TEMPERATURE RISE WITHIN THE RANGE SPECIFIED ON THE RATING PLATE.
- The chart is for information only. For satisfactory operation, external static pressure must not exceed values shown on the rating plate. The shaded area insicated ranges in excess of maximum static pressure allowed when heating.
- The dashed (---) areas indicate a temperature rise not recommended for this model.
- The above chart is for U.S. furnaces installed at 0' - 2,000'. At higher altitudes, a properly de-rated unit will have approximatley the same temperature rise at a particular CFM, while ESP at the CFM will be lower.

BLOWER PERFORMANCE SPECIFICATIONS

BTU OUTPUT vs TEMPERATURE RISE CHART

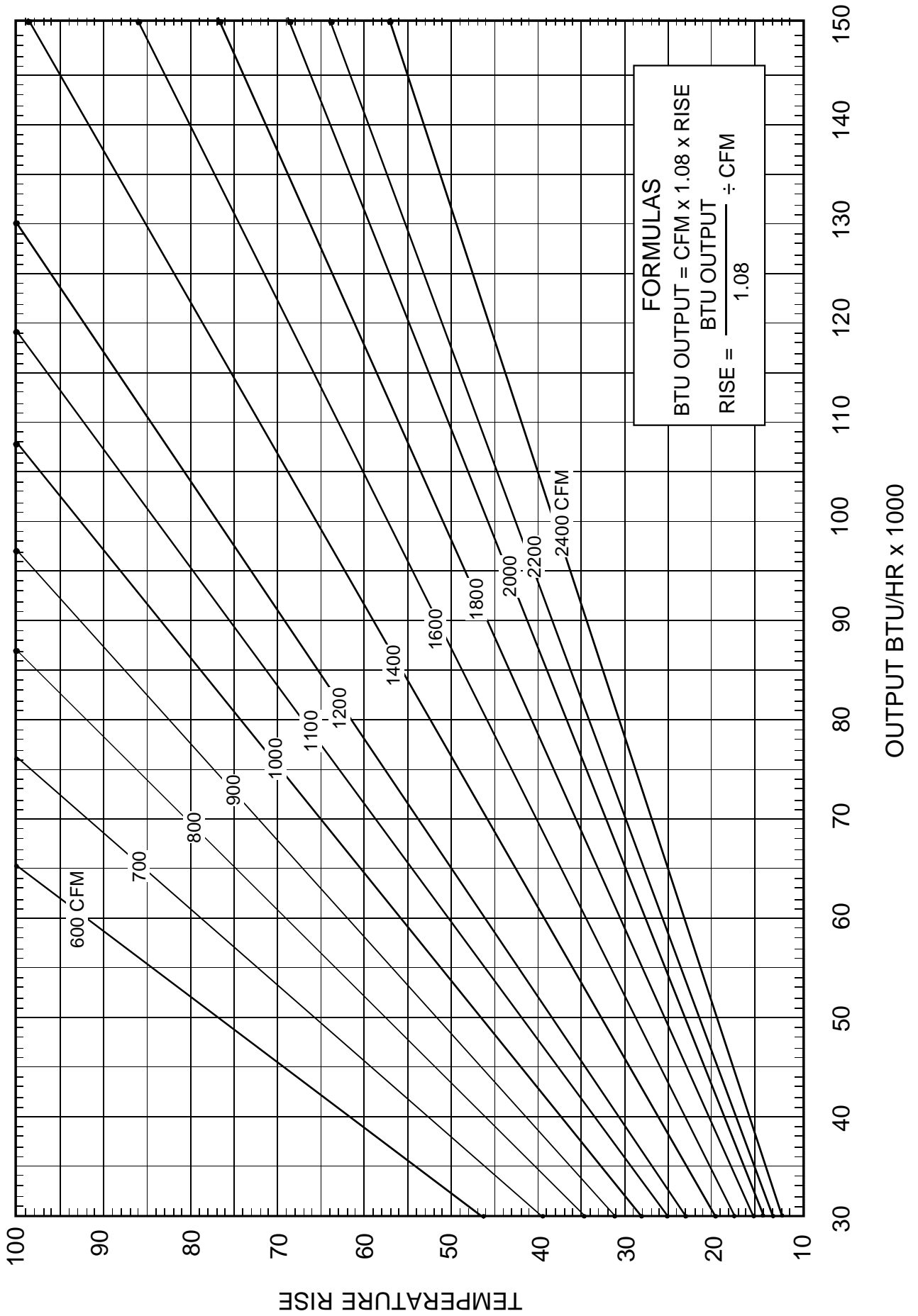



WARNING

HIGH VOLTAGE!

DISCONNECT ALL POWER BEFORE SERVICING OR INSTALLING THIS UNIT. MULTIPLE POWER SOURCES MAY BE PRESENT. FAILURE TO DO SO MAY CAUSE PROPERTY DAMAGE, PERSONAL INJURY OR DEATH.

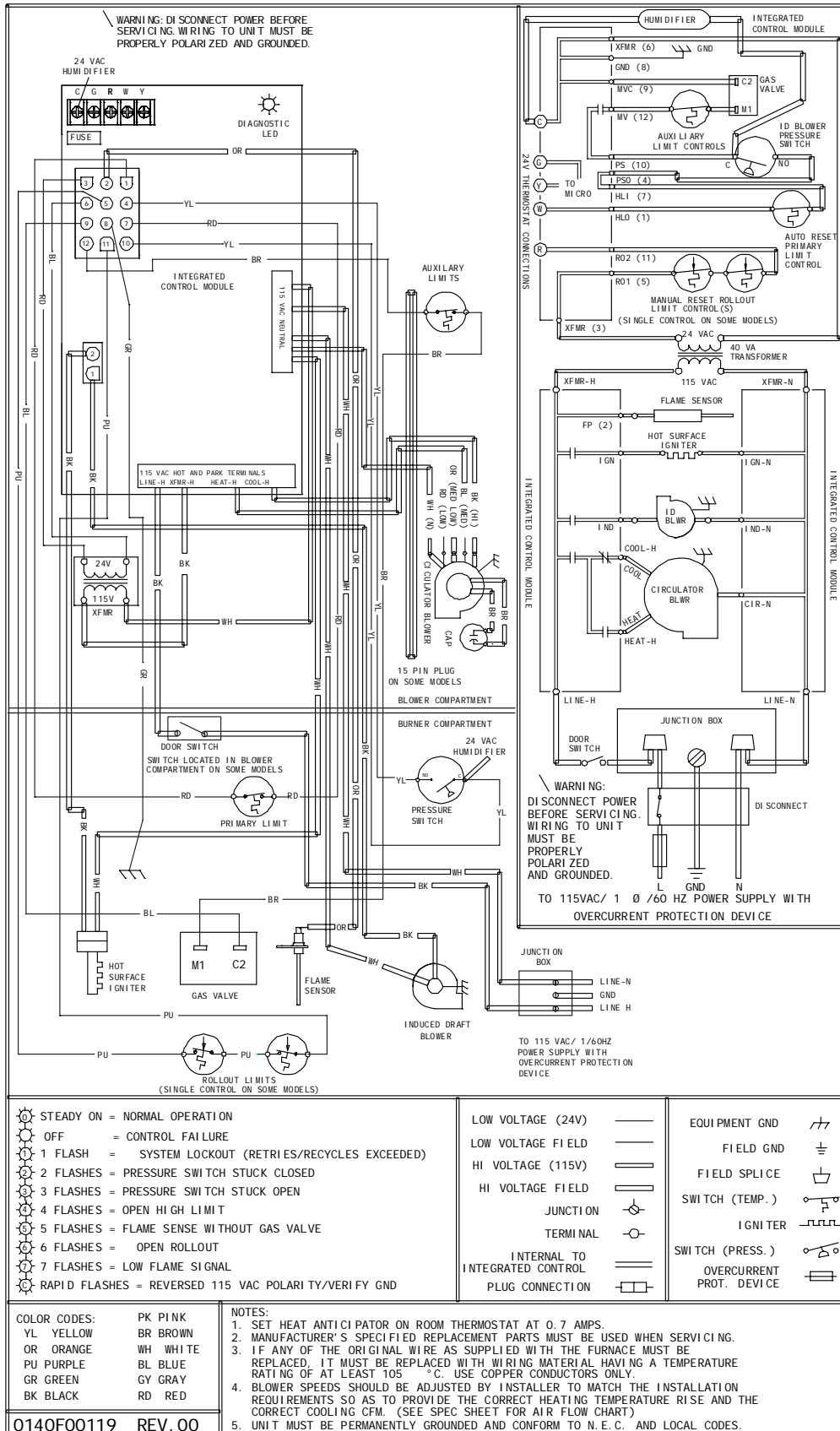

Wiring is subject to change, always refer to the wiring diagram on the unit for the most up-to-date wiring.

WARNING

HIGH VOLTAGE!
 DISCONNECT ALL POWER BEFORE SERVICING OR INSTALLING THIS UNIT. MULTIPLE POWER SOURCES MAY BE PRESENT. FAILURE TO DO SO MAY CAUSE PROPERTY DAMAGE, PERSONAL INJURY OR DEATH.

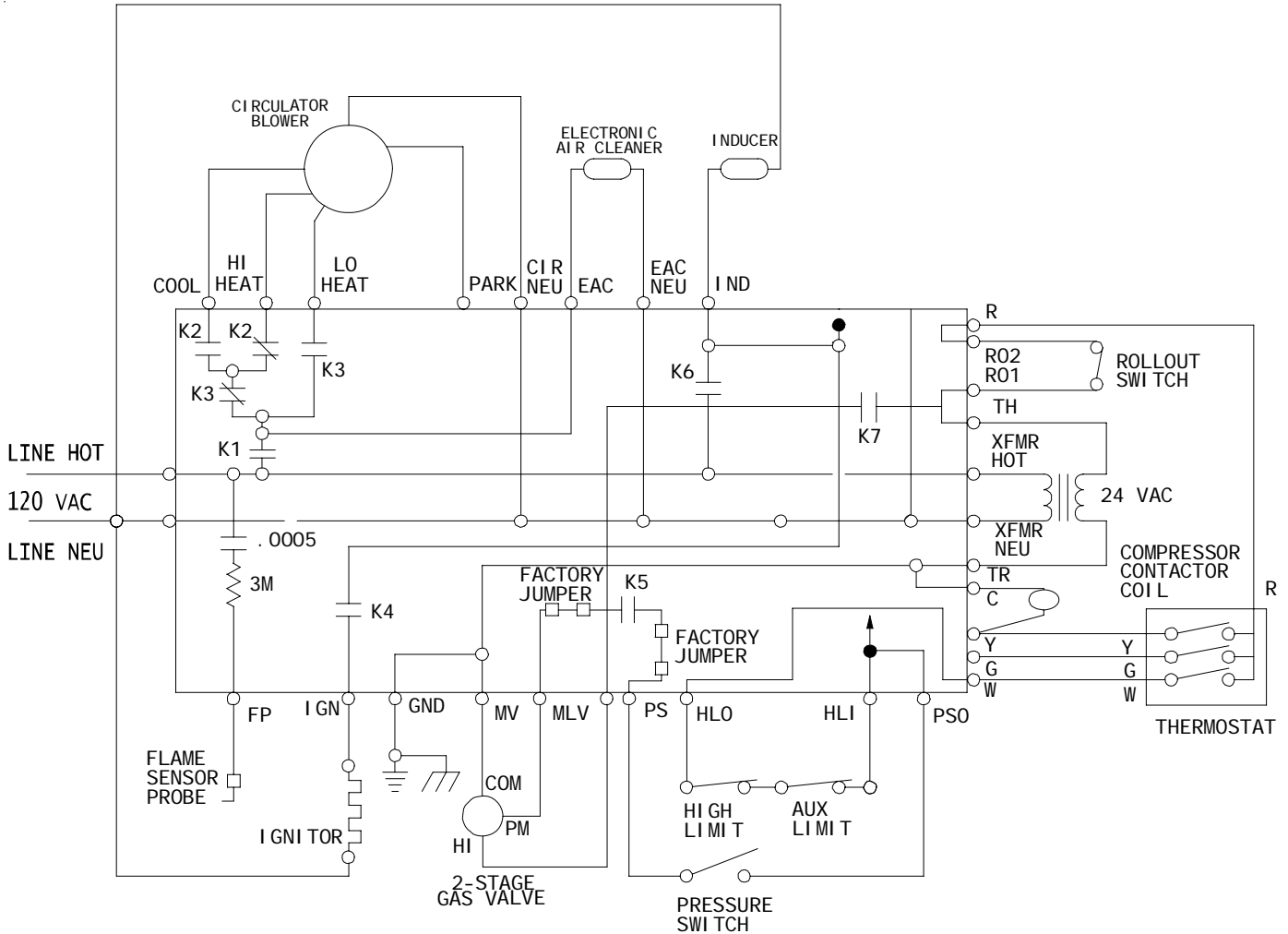

TYPICAL SCHEMATIC
GMS8 * & GHS8 ____ ** MODEL FURNACES
WR 50M56-289 INTEGRATED IGNITION CONTROL

This schematic is for reference only. Not all wiring is as shown above. Always refer to the appropriate wiring diagram for the unit being serviced.